



tecnoplas[®]
PVC DOOR & WINDOW SYSTEMS

GROSSTEC

Turkey's window to the world

Herşey insan için

Tecnoplas, sektöründe dünyada oluşan bilgi birikimi ve deneyimi ile teknolojik gelişmeleri en son aşamalarıyla yakından izleyerek, hem tüketicilere önemli katkılar sağlıyor; hemde genç insanların yıllardır artarak güçlenen istihdam beklentilerine yeni olanaklar sunuyor.

Tecnoplas, büyük bir duyarlılık ve sorumluluk bilinci ile yürüttüğü yatırım ve üretim politikalarında, “Önce insana saygı” yı esas almakta, çevreye ve doğaya saygıyı da bunun vazgeçilmez bir gereği saymaktadır.

Tecnoplas’ın üretim politikasındaki temel hedefi, sektörel düzeyde profil üretiminden, yan mamullere kadar, bütün üretim kademelerinde oluşan tüm istek ihtiyaçları karşılamak, sektörde dışa bağımlılığı ortadan kaldırmaktır.

Tecnoplas, PVC kapı-pencere sistemlerinde geliştirdiği özgün detay projelerinde, sınırsız çeşitliliğin, alternatifler sunmanın yanısıra, zengin renk ve laminasyon seçenekleri ile üreticiden tüketiciye eksiksiz hizmet vermeyi de bir görev bilinci saymaktadır.

Tecnoplas, kalitesi ve üretim standartlarındaki teknolojik avantajları yanında, AR-GE bölümünde geleceğe dönük vizyonu ile yarınlara koşullarına tam bir güven duygusu ve başarı inancı ile hazırlanmaktadır.

Tecnoplas, insanların her zaman en iyiye, en güzele ve en mükemmelere değer olduğuna inanmaktadır.

Everything is for a comfortable life

Tecnoplas has been both contributing to its consumers on a large scale by following the recent technological developments with its experience and information accumulated in its sector in the world. and has presented new alternatives to young people expecting new employment opportunities.

Tecnoplas puts respect to humanity at first place and considers that being environment and nature conscious is basic necessity in its investment and production politics. which is carried out with great sensitivity and responsibility. Basic goal of Optimaplas in its production politics is to supply all the requests and needs from frame production in sectorial level to side production which has formed in its sector and give end to foreign dependence.

Tecnoplas has presented a great number of varieties and alternatives in original projects. which developed for PVC door and window systems. In addition to this. it considers that it has a basic and private duty in providing consumers needs with various colours and illumination options.

Tecnoplas is proud of being prepared for tomorrow’s conditions with a developed research center and a good guidance for future and self confidence in addition to its high quality in manufacturing standard and technological advantages.

Tecnoplas believes sincerely that men have always deserved to have the most beautiful and the best of everything.



tecnoplas

(ST 1410) "GROSSTEC" Pervazlı Kasa Profili (Contalı)
(ST 1410) "GROSSTEC" Edge Frame Profile (Seal)
(ST 1410) "GROSSTEC" Профиль коробки с карнизом (с уплотнителем)
(ST 1410) بروفيل الصندوق ذو البرواظ (مع الفتيل)

Ö : 1/1
S : 1/1
P-P : 1/1

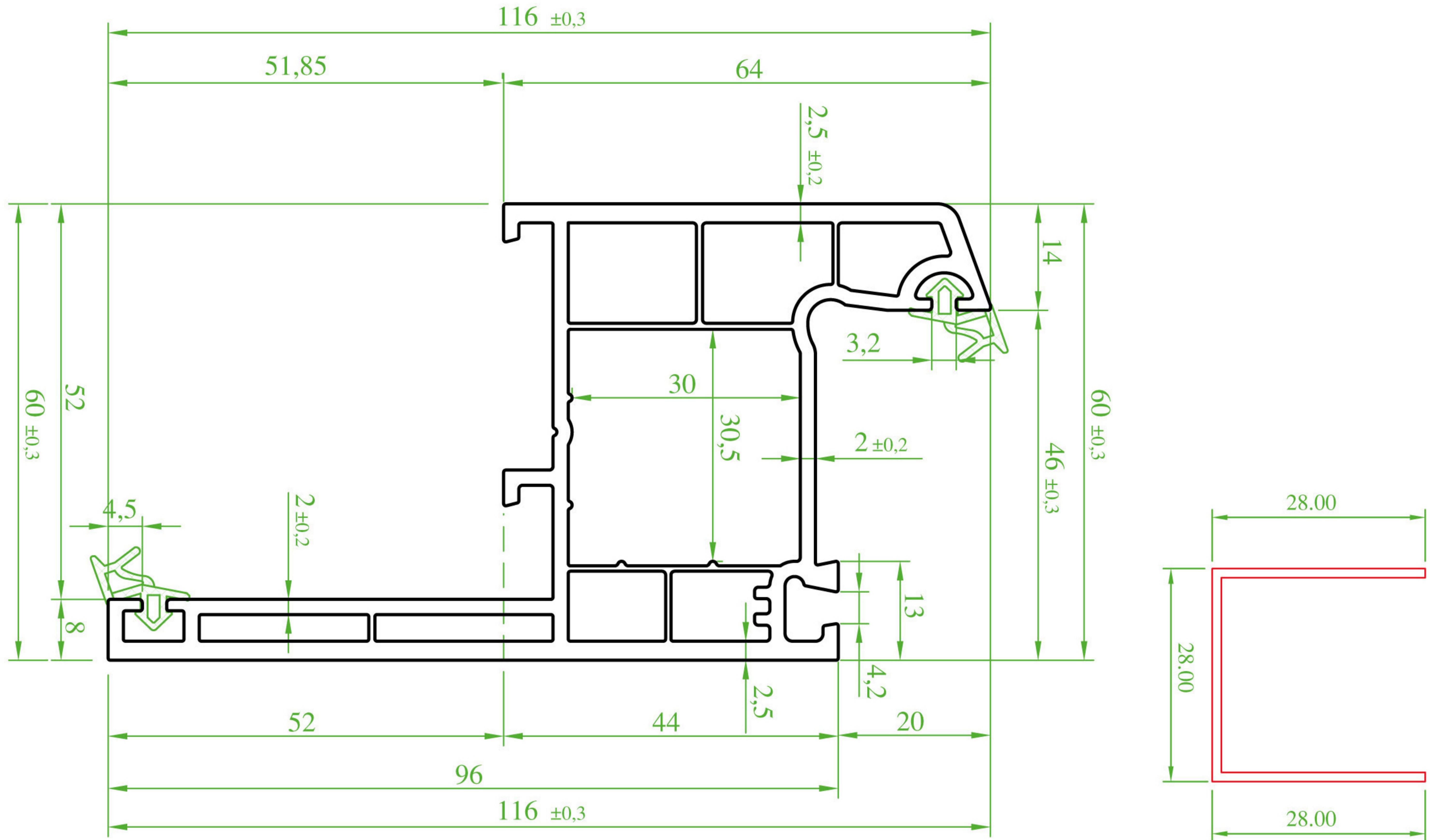

(ST1110) "GROSSTEC" Kasa Profili (Contalı)
(ST1110) "GROSSTEC" Frame Profile (Seal)
(ST1110) "GROSSTEC" Профиль коробки (с уплотнителем)
(ST1110) بروفيل الصندوق (مع فتيل)

Ö:1/1
S:1/1
P-P : 1/1

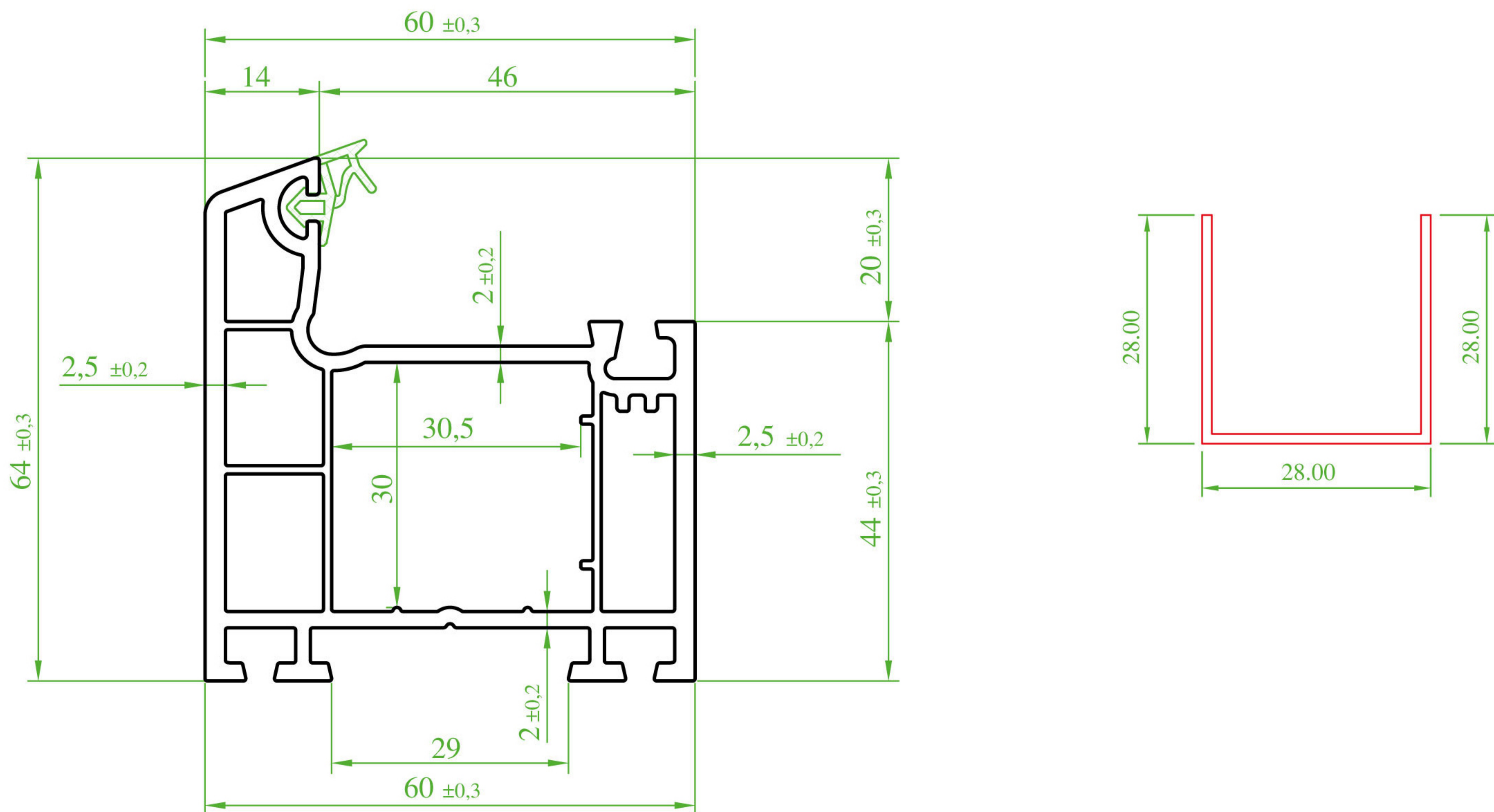

(ST 1210) "GROSSTEC" Orta kayıt Profili (Contalı)
 (ST 1210) "GROSSTEC" Mullion profile (Seal)
 (ST 1210) "GROSSTEC" Профиль импоста (с уплотнителем)
 (ST 1210) بروفيل المنصف الثابت (مع الفتيل)

Ö:1/1
 S:1/1
 P-P : 1/1

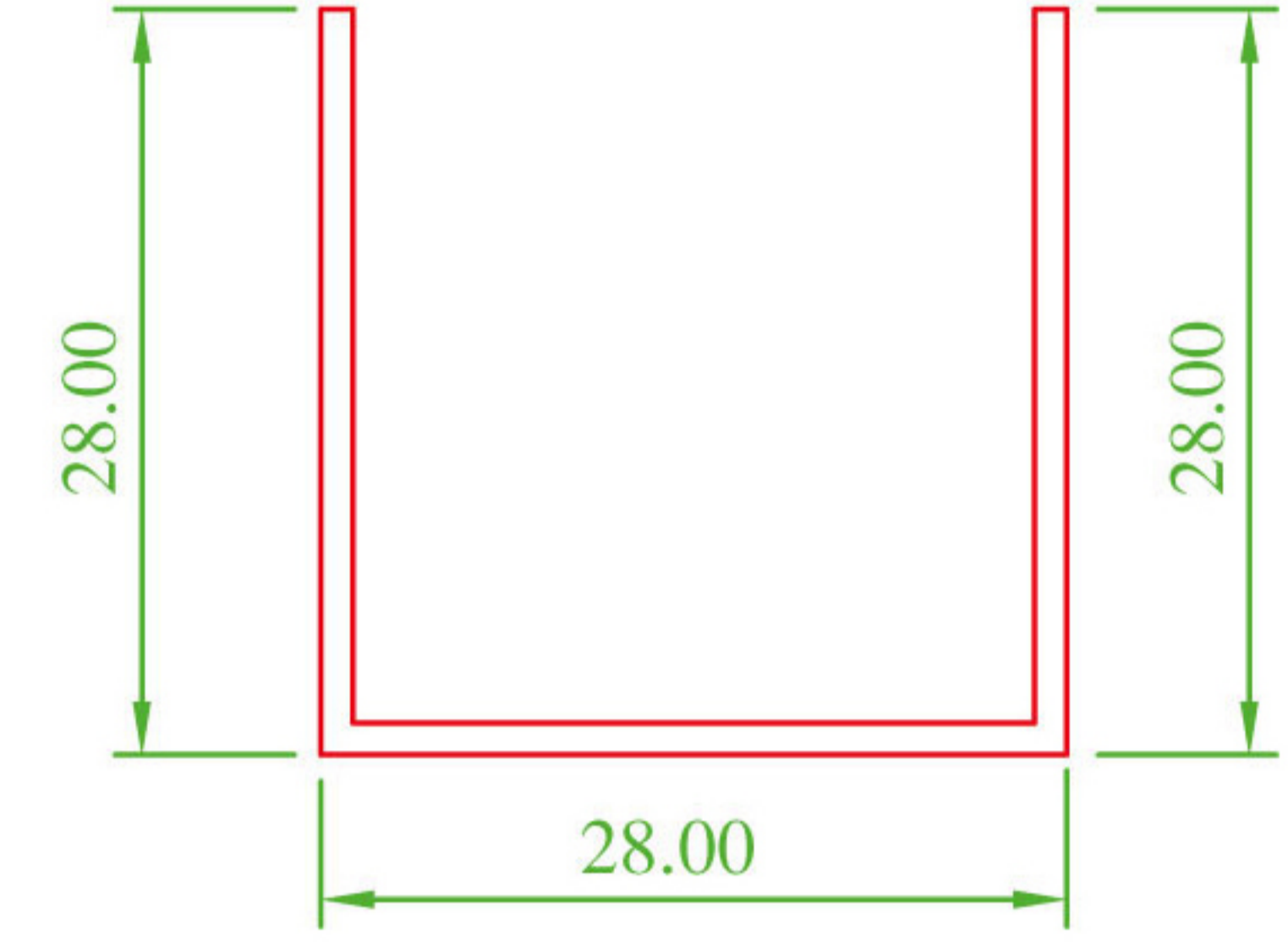
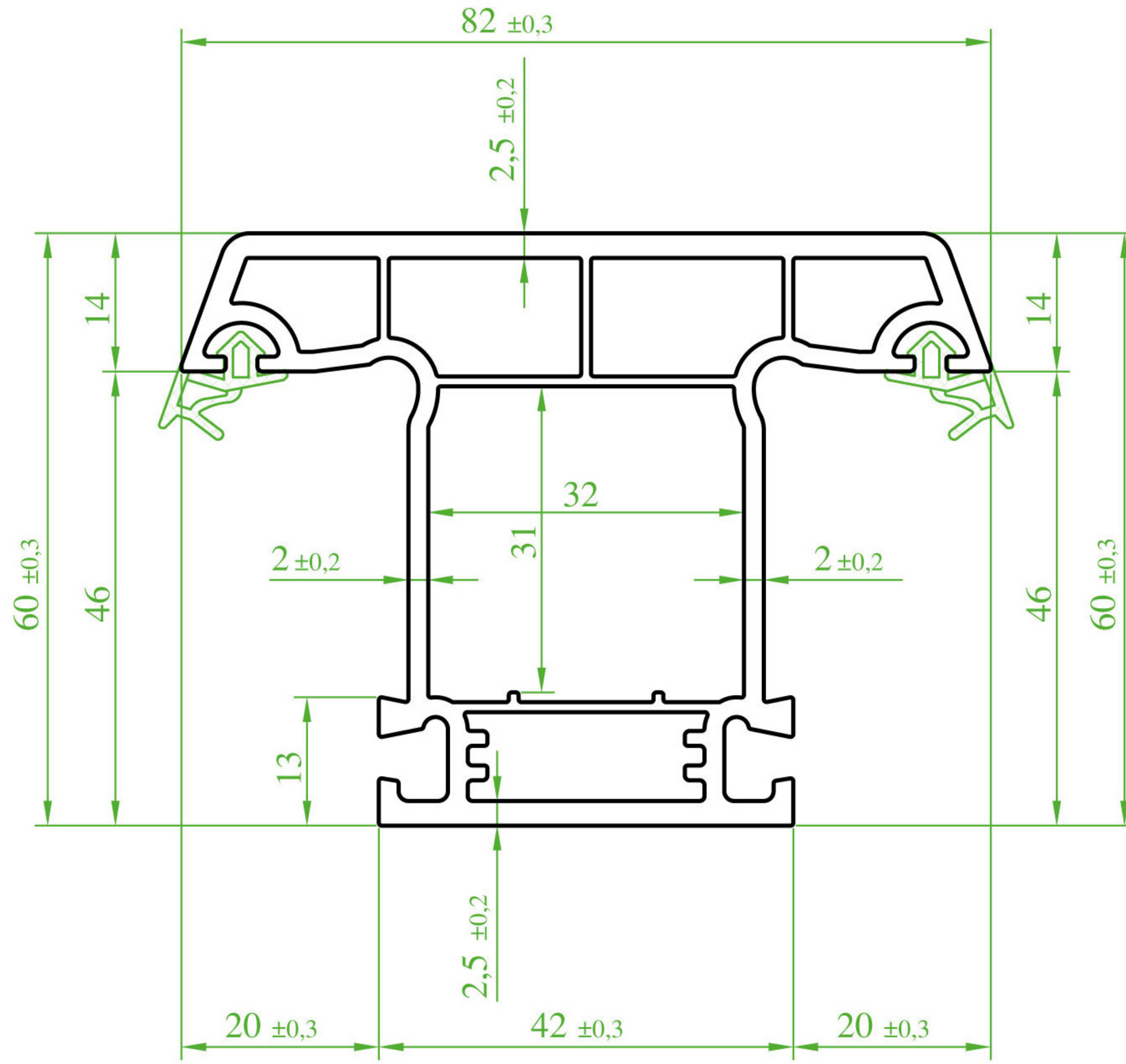

(ST 1310) "GROSSTEC" Kanat Profili (Contalı)
 (ST 1310) "GROSSTEC" Sash Profile (Seal)
 (ST 1310) "GROSSTEC" Профиль створки (с уплотнителем)
 (ST 1310) بروفيل الضرفه (مع الفتيل)

Ö:1/1
 S:1/1
 P-P : 1/1

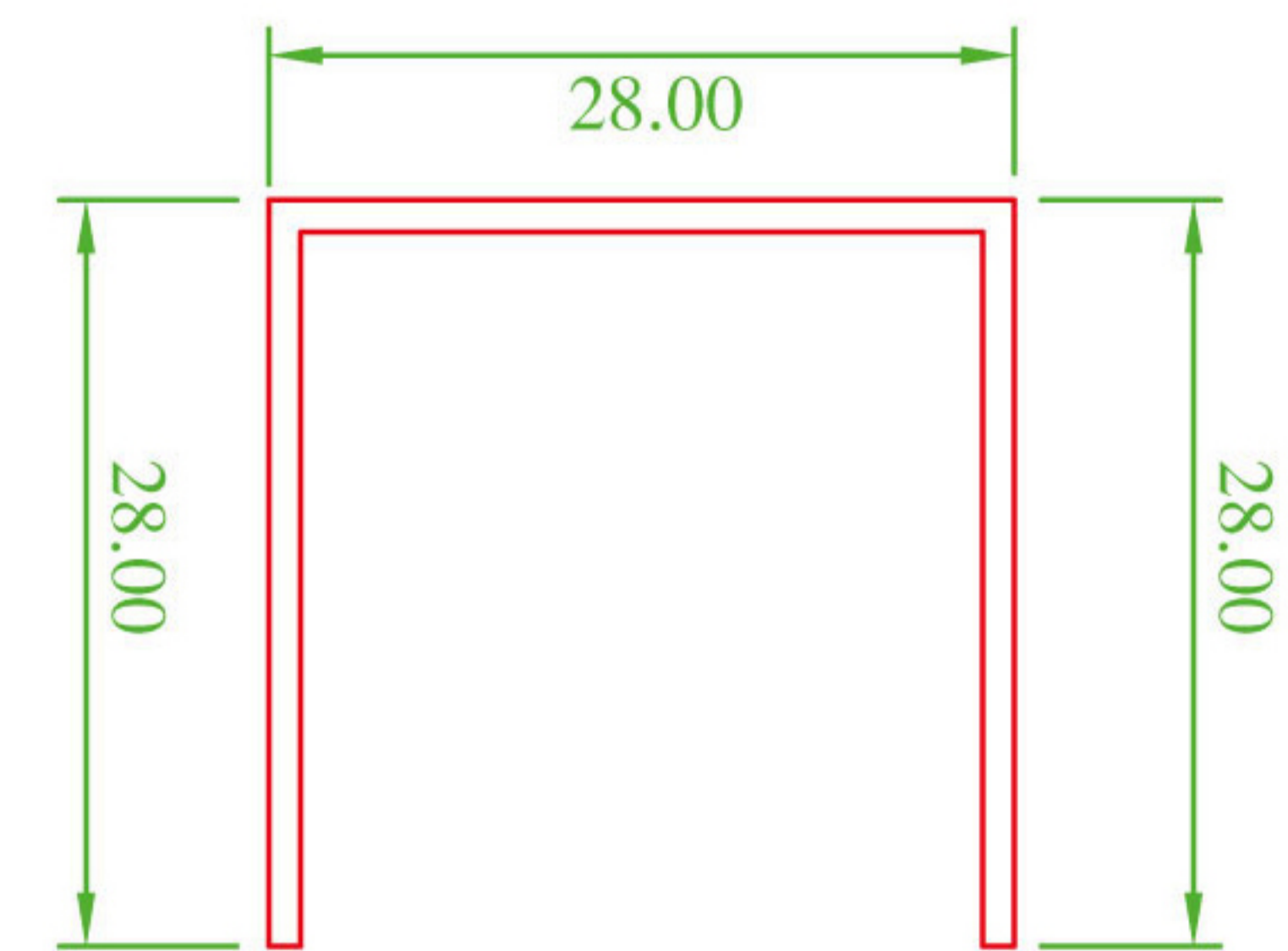
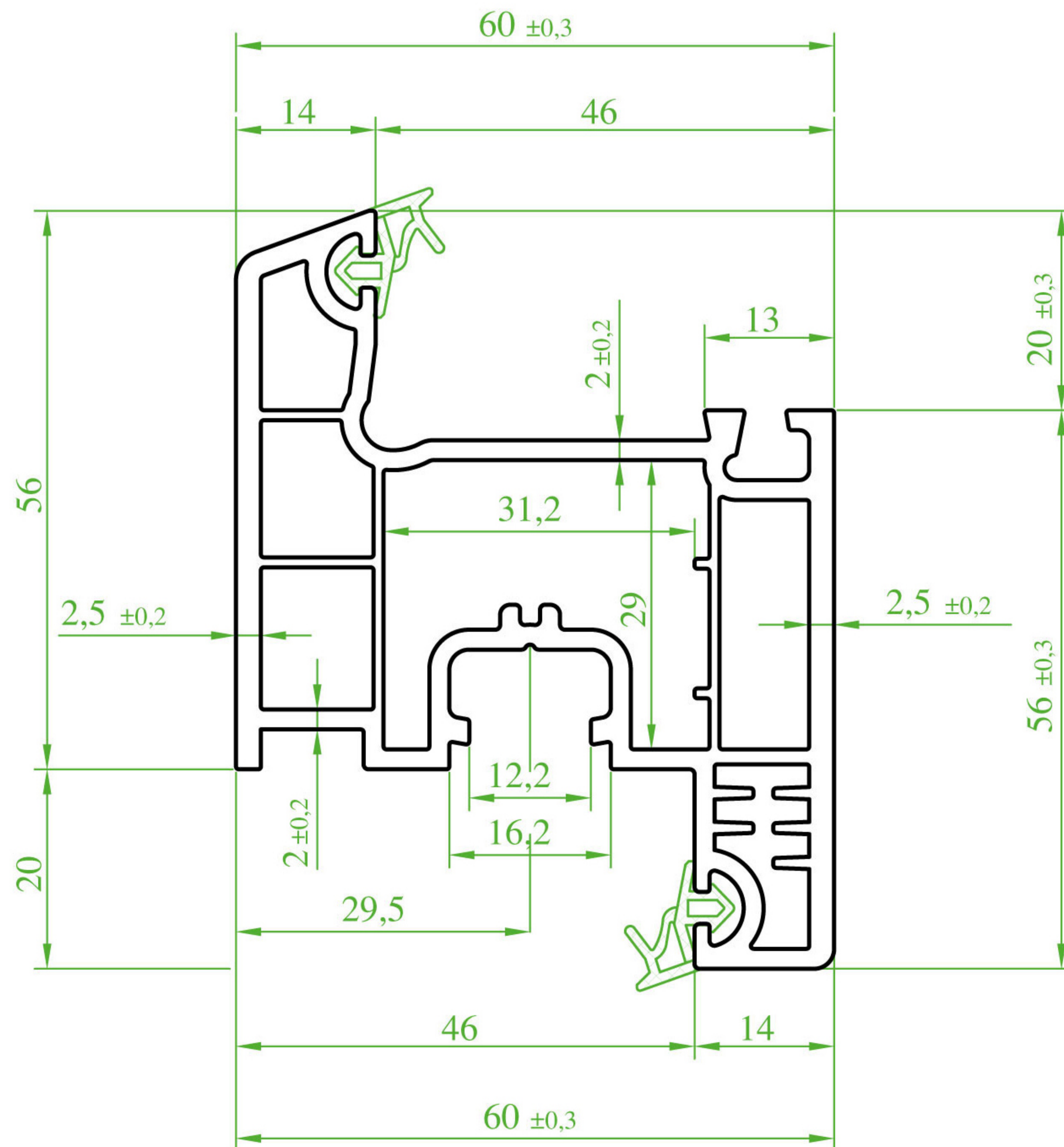

(ST 8700) "GROSSTEC" Yeni Hareketli Orta Kayıt Profili Contalı

Ö : 1/1

(ST 8700) "GROSSTEC" New Overhung Profile Seal

S : 1/1

(ST 8700) "GROSSTEC" Профиль подвижного импоста (новый) с уплотнителем

P-P : 1/1

(ST 8700) بروفيل المنصّف المتحرك الجديد (مع الفتيل)

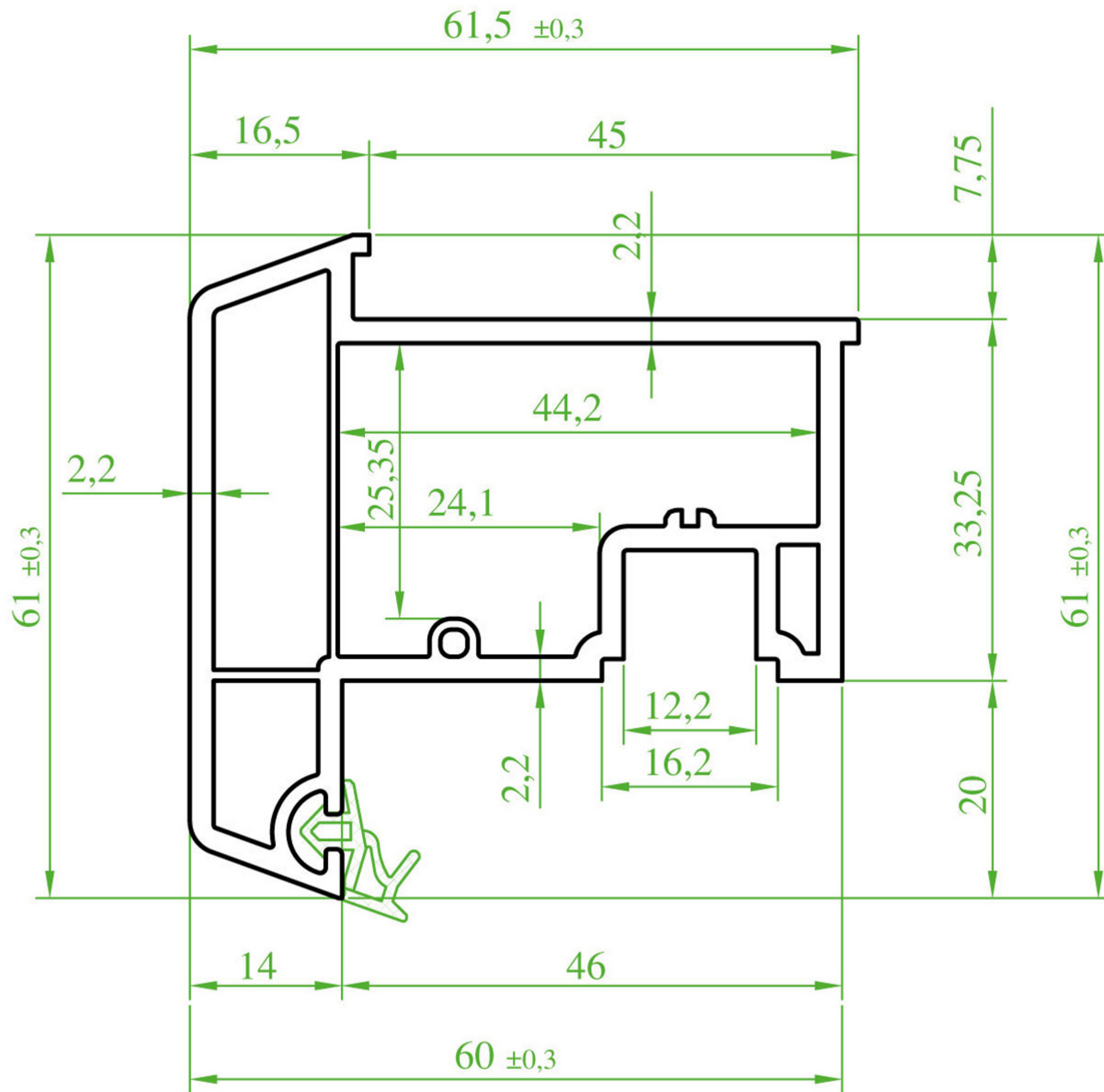

Hareketli Orta Kayıt Profili Kapağı
Overhung Profile Cover
Крышка профиля подвижного импоста
غطاء بروفيل المنصّف المتحرك

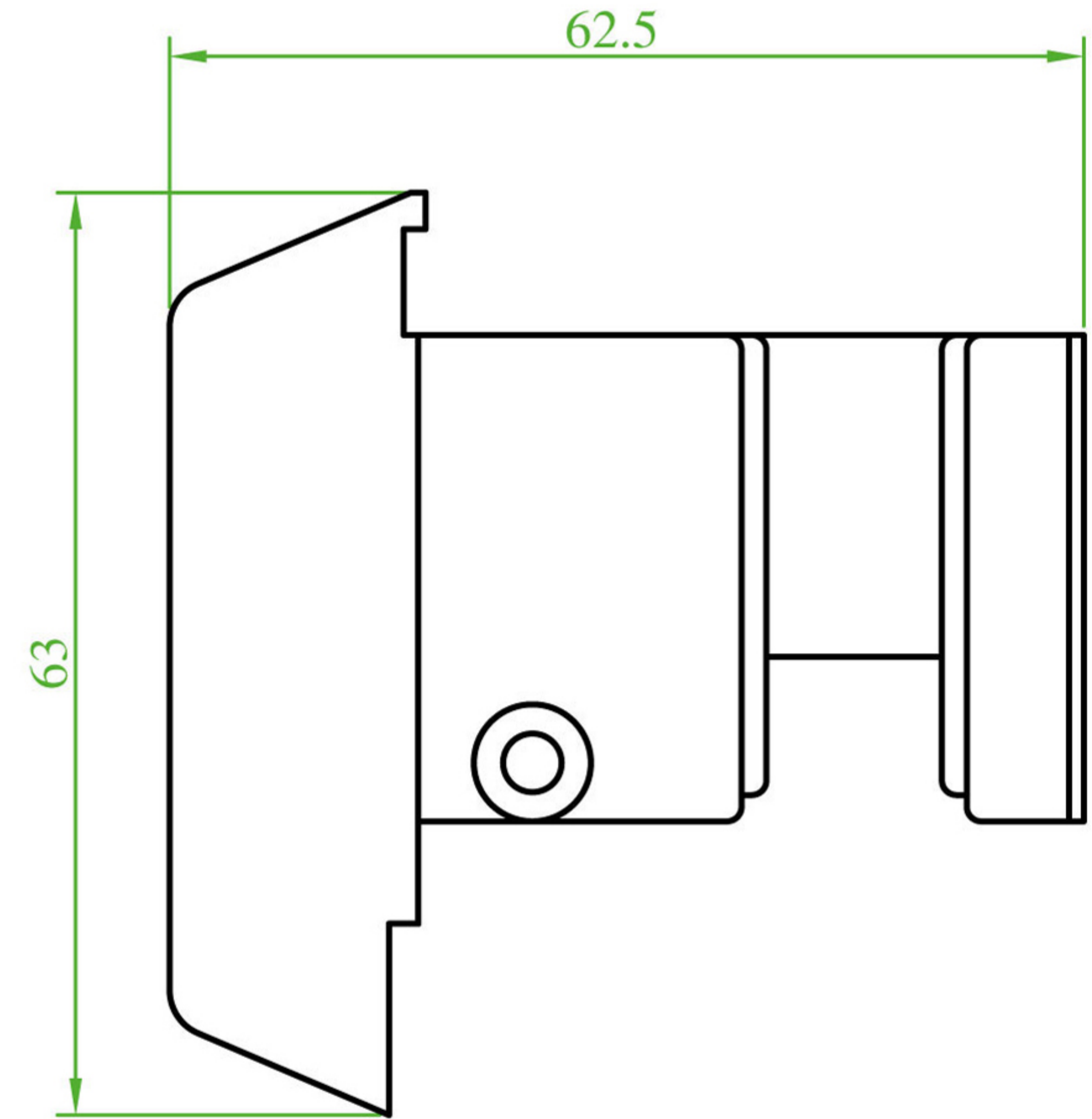

(ST 2410) "GROSSTEC" Kapı Kanat Profili (Contalı)

Ö : 1/1

(ST 2410) "GROSSTEC" Door Sash Profile (Seal)

S : 1/1

(ST 2410) "GROSSTEC" Профиль дверного полотна (с уплотнителем)

P-P : 1/1

(ST 2410) بروفيل ضرفه باب (مع الفتيل)

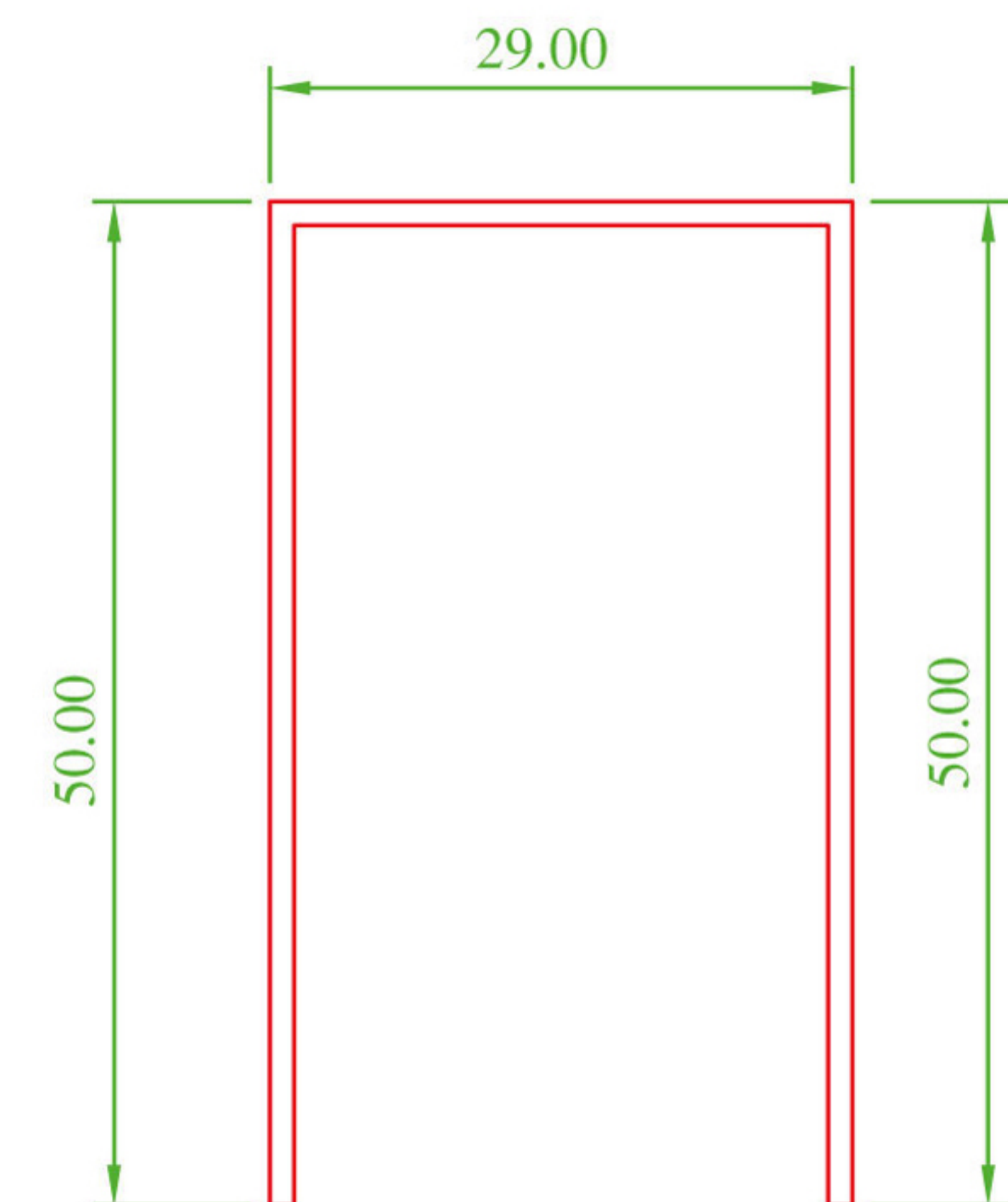
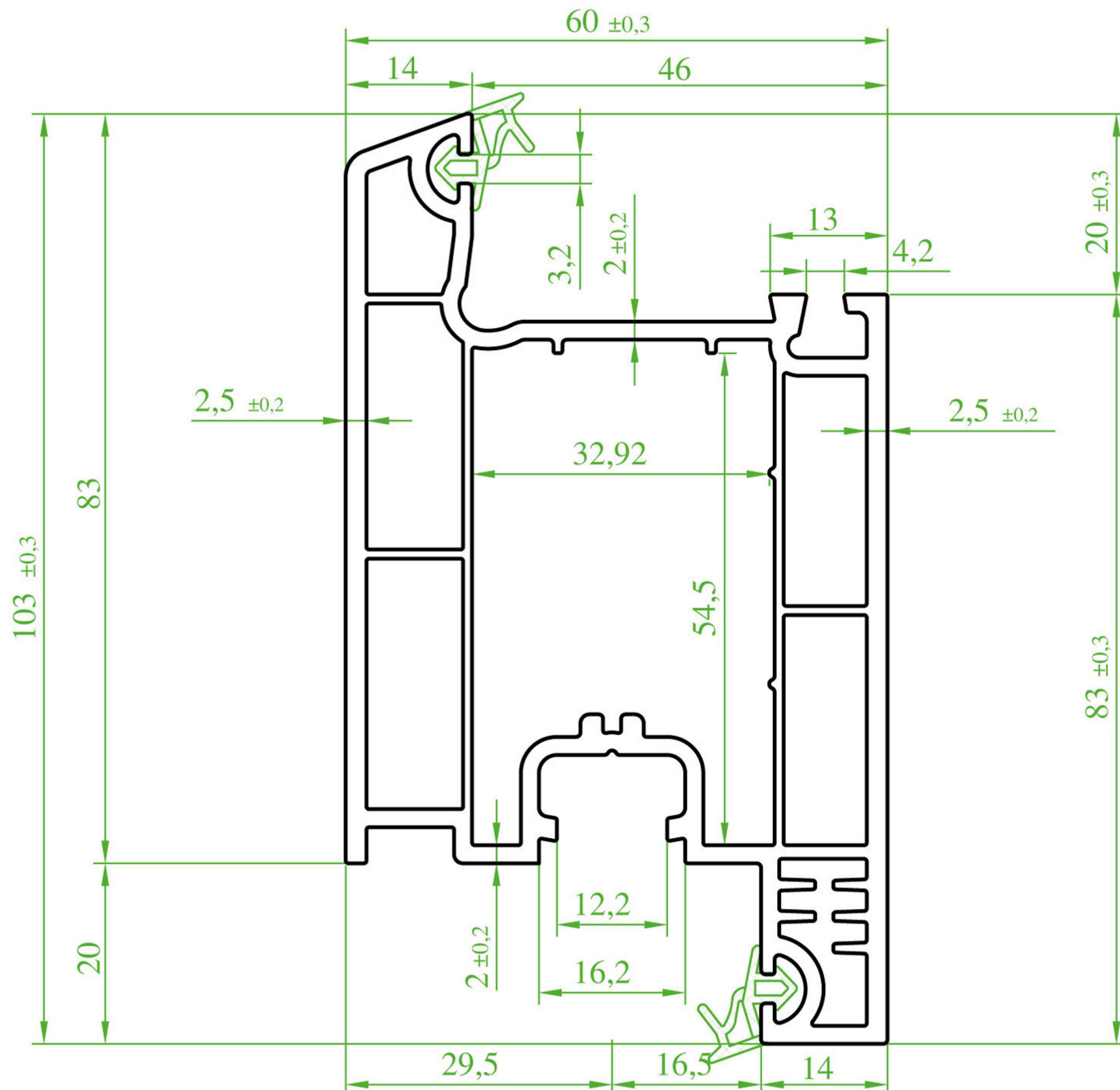

(ST 8410) "GROSSTEC" Kapı Kanat Profili (Contalı)
(ST 8410) "GROSSTEC" Door Sash Profile (Seal)
(ST 8410) "GROSSTEC" Профиль дверного полотна (с уплотнителем)
(ST 8410) بروفیل ضرفه باب (مع الفتیل)

Ö : 1/1
S : 1/1
P-P : 1/1

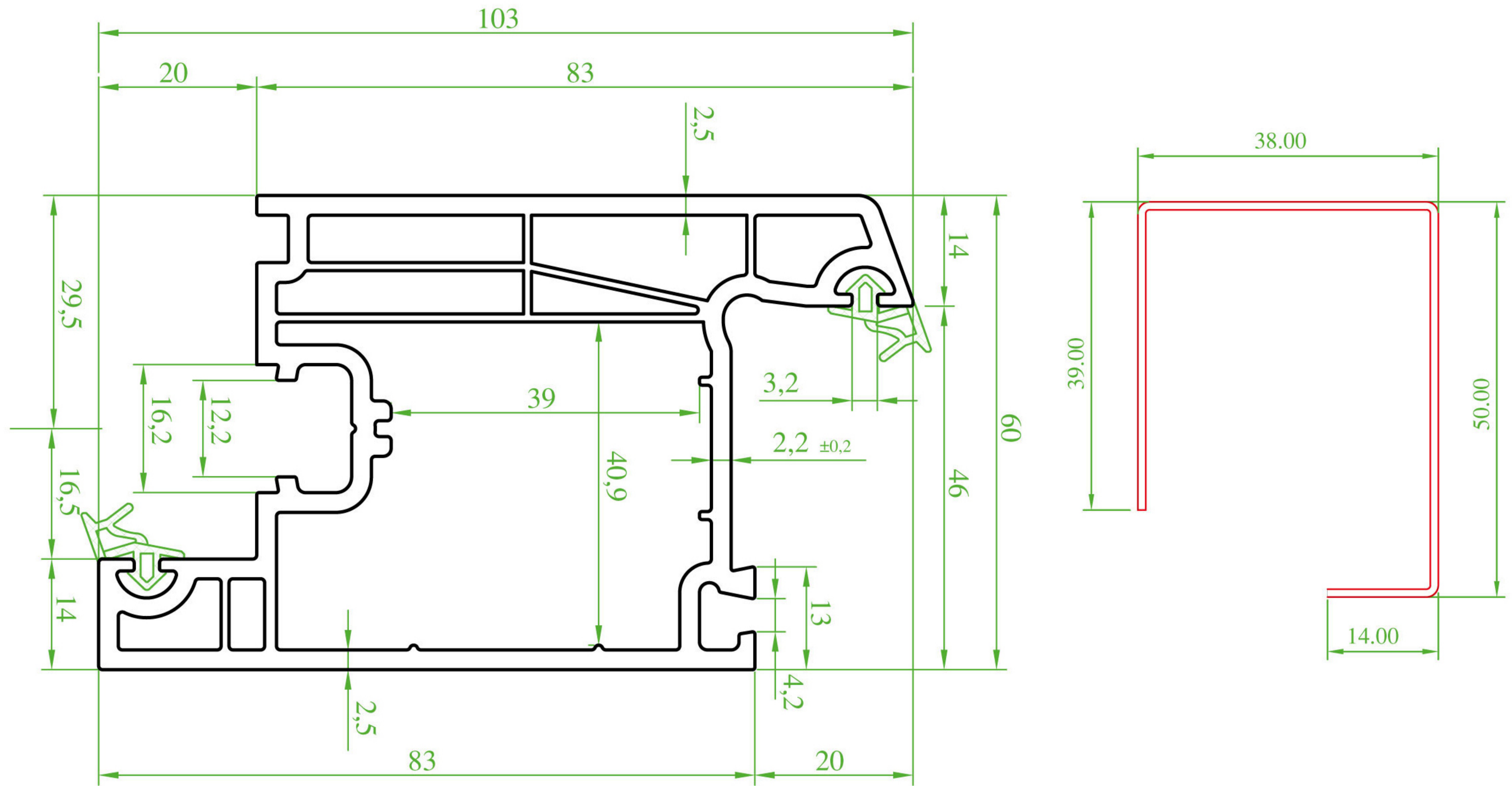

(ST 8460) "GROSSTEC" Dışa Açılır Kapı Profili (Contalı)
(ST 8460) "GROSSTEC" Outward Opening Door Sash Profile (Seal)
(ST 8460) "GROSSTEC" Профиль двери открывающейся наружу (с уплотнителем)
(ST 8460) بروفیل باب یفتح للخارج (مع الفتیل)

Ö : 1/1
S : 1/1
P-P : 1/1

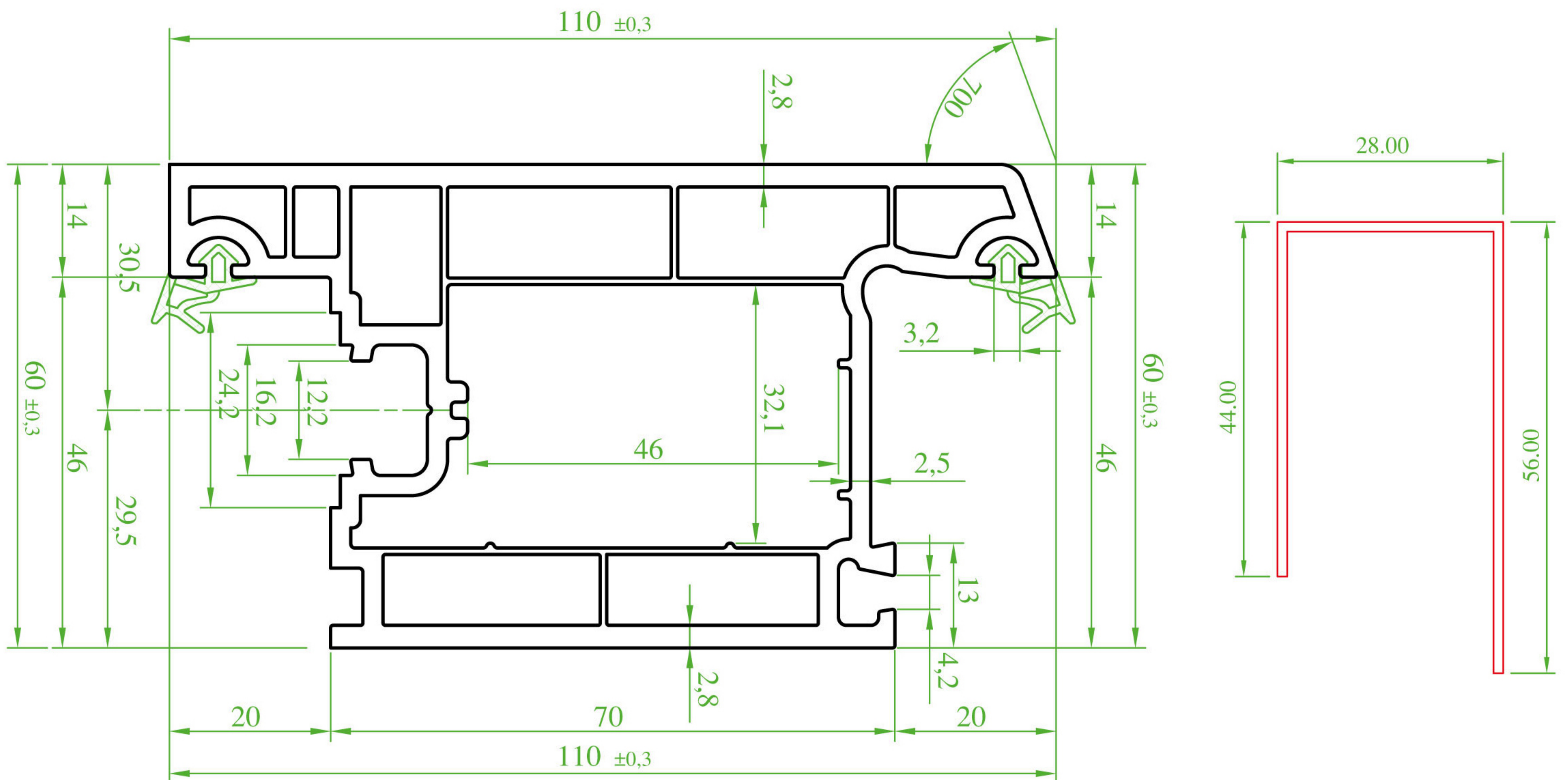

(ST 6650)

“GROSSTEC” Yap. Con. Çift Cam Çıtası” (20 mm)

“GROSSTEC” Double Glass Lath with Adhesive Seal (20 mm)

“GROSSTEC” Приклеивающийся штапик с уплотнителем для двойного стекла” (20 мм)

ماسکه زجاج (مزدوج) 20 ملم مع فتيل لاصق

Ö : 1/1

S : 1/1

P-P:1/1

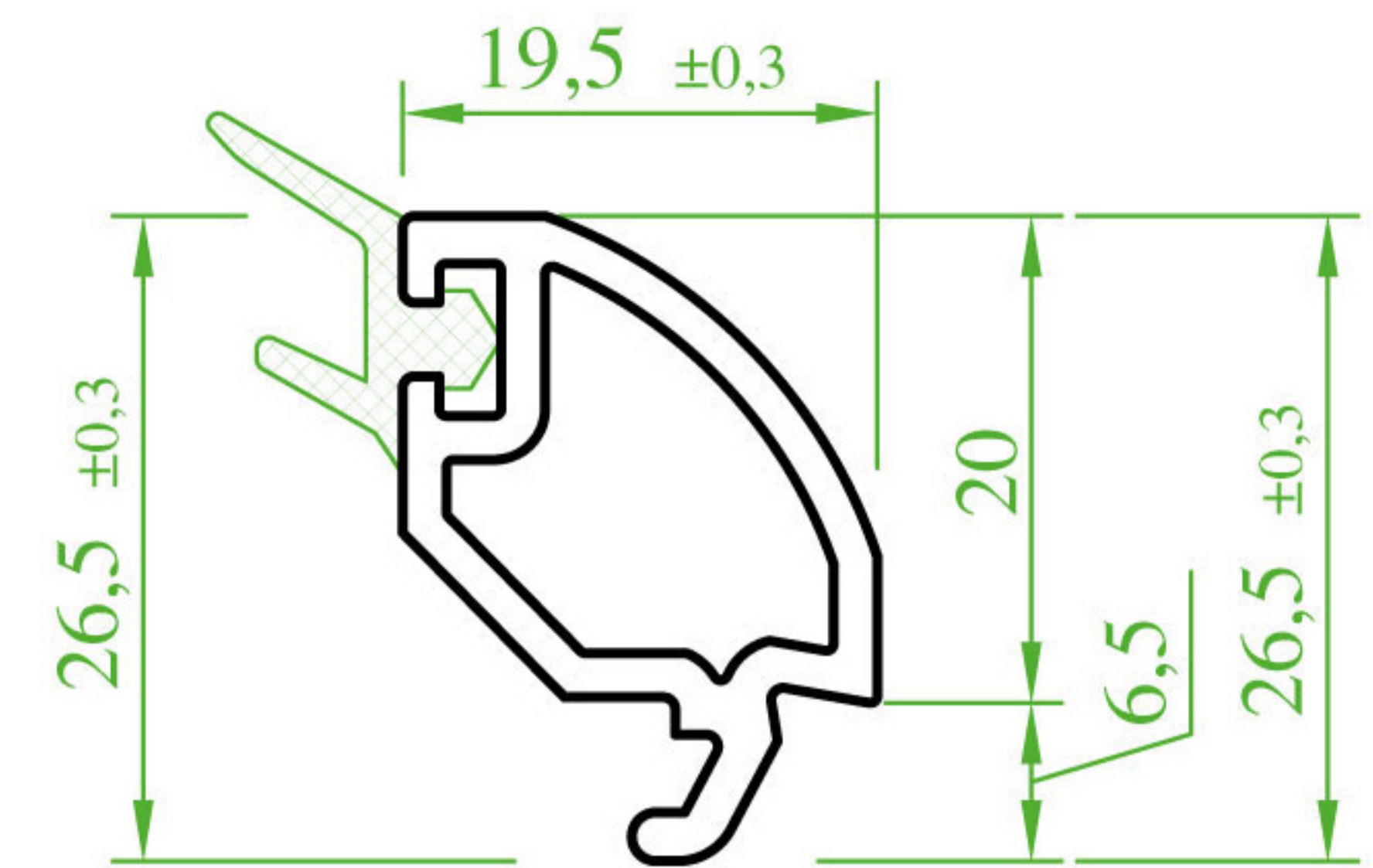

(ST 6655)

“GROSSTEC” Yap. Con. Dek. Çift Cam Çıtası” (20 mm)

“GROSSTEC” Decorative Double Glass Lath with Adhesive Seal (20 mm)

“GROSSTEC” Декоративный штапик для двойного стекла, с приклеивающимся уплотнителем” (20 мм)

ماسکه زجاج (مزدوج) 20 ملم موديل ديکوري مع فتيل لاصق

Ö:1/1

S: 1/1

P-P:1/1

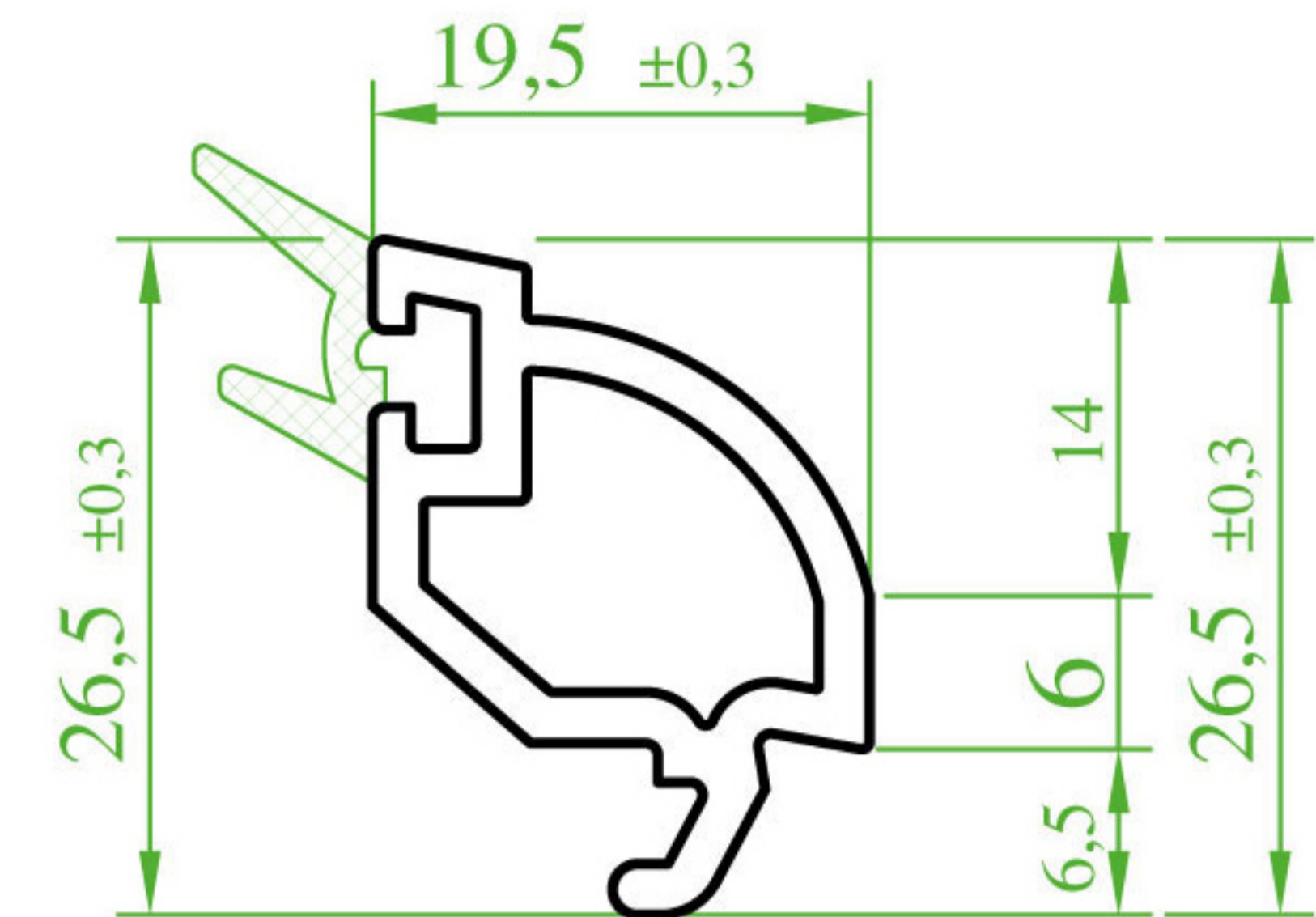

(ST 6640)

“GROSSTEC” Yap. Con. Çift Cam Çıtası” (20 mm)

“GROSSTEC” Double Glass Lath with Adhesive Seal (20 mm)

“GROSSTEC” Приклеивающийся штапик с уплотнителем для двойного стекла” (20 мм)

ماسکه زجاج (مزدوج) 20 ملم مع فتيل لاصق

Ö : 1/1

S : 1/1

P-P:1/1

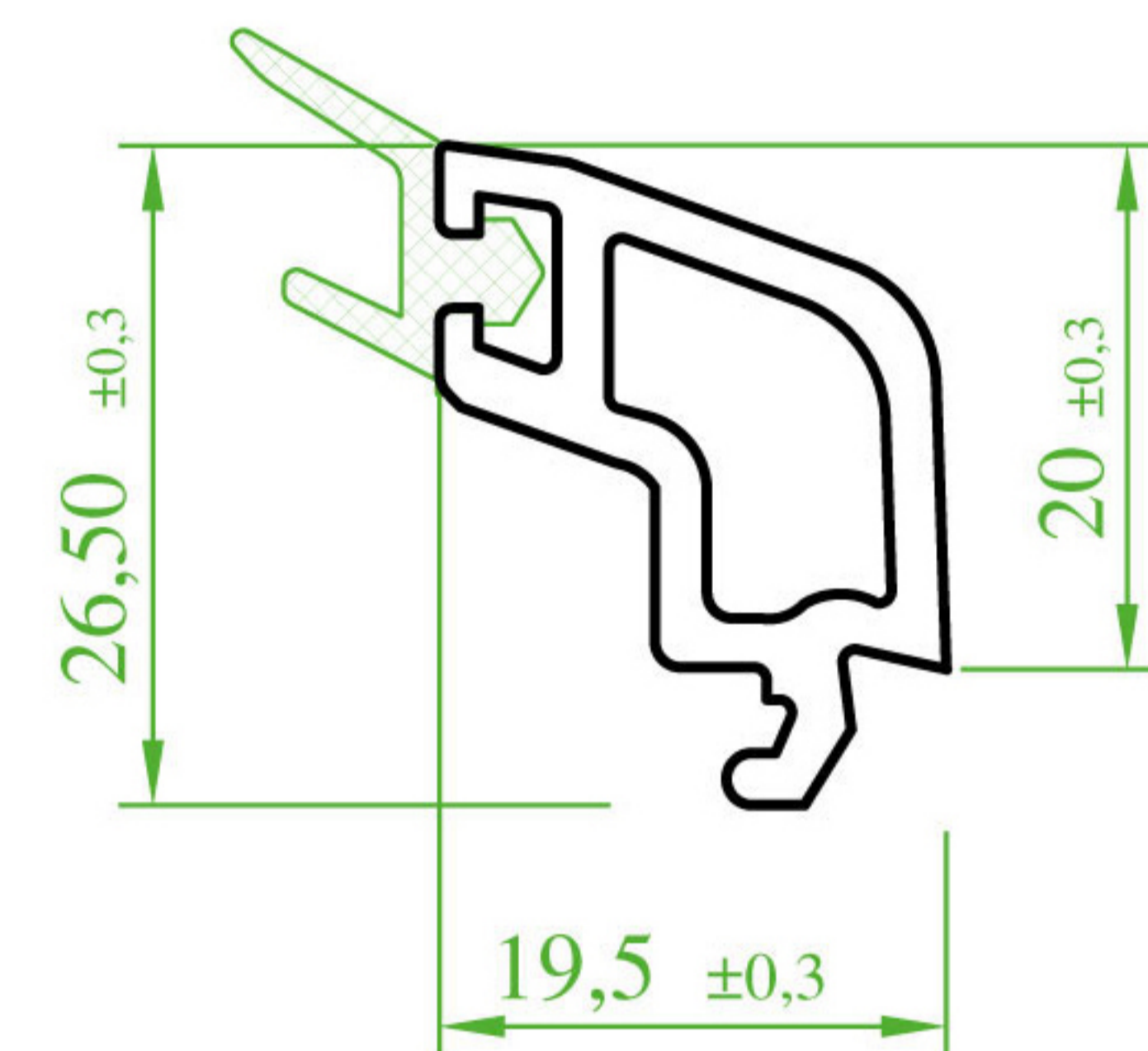

(ST 6620)

“GROSSTEC” Yap. Con. Dek. Çift Cam Çıtası” (20 mm)

“GROSSTEC” Decorative Double Glass Lath with Adhesive Seal (20 mm)

“GROSSTEC” Декоративный штапик для двойного стекла, с приклеивающимся уплотнителем” (20 мм)

ماسکه زجاج (مزدوج) 20 ملم موديل ديکوري مع فتيل لاصق

Ö:1/1

S: 1/1

P-P:1/1

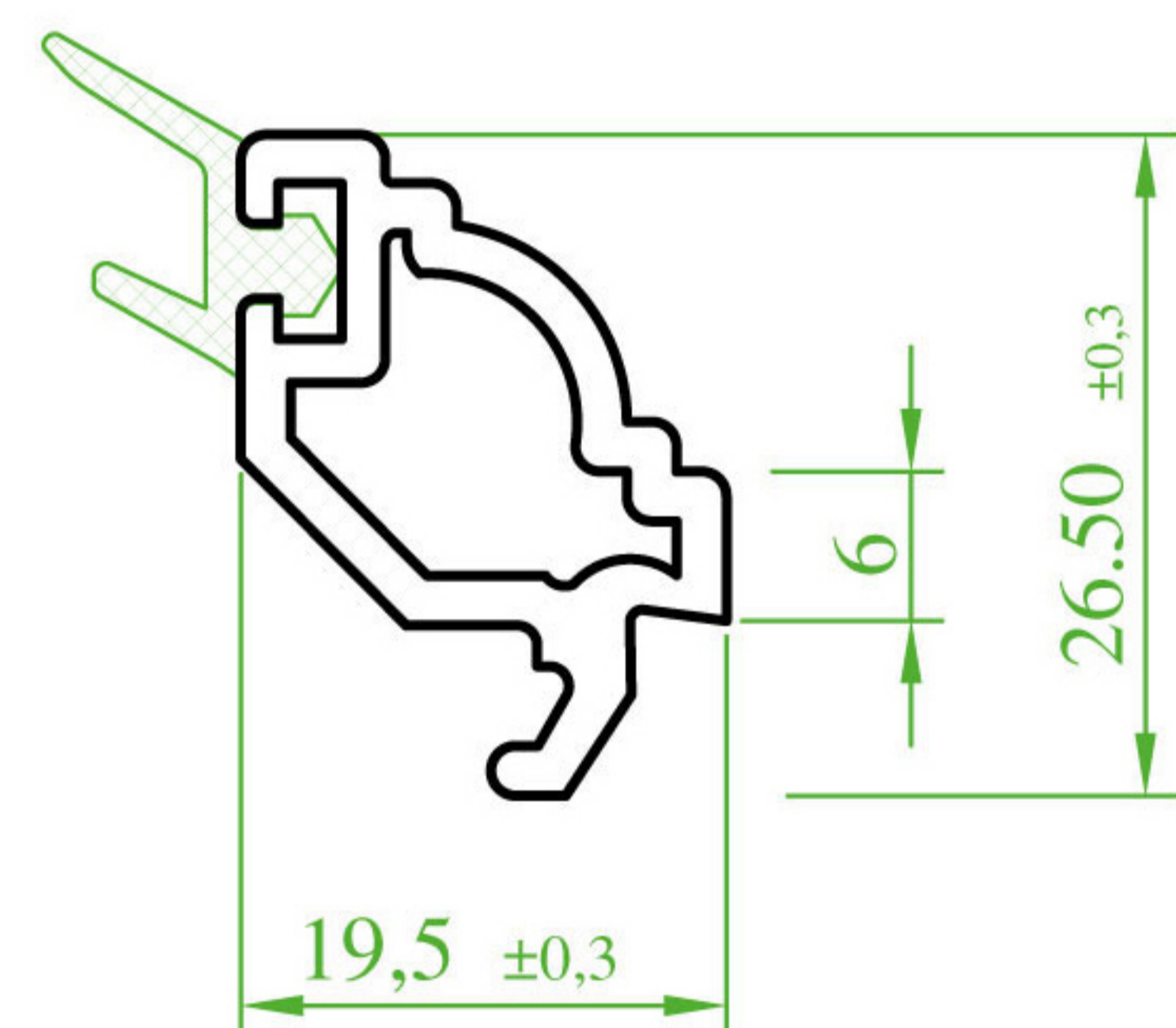

(ST 6630)

“GROSSTEC” Yap. Con. Çift Cam Çıtası” (24 mm)

“GROSSTEC” Double Glass Lath with Adhesive Seal (24 mm)

“GROSSTEC” Приклеивающийся штапик с уплотнителем для двойного стекла” (24 мм)

ماسکه زجاج (مزدوج) 24 ملم مع فتيل لاصق

Ö : 1/1

S : 1/1

P-P:1/1

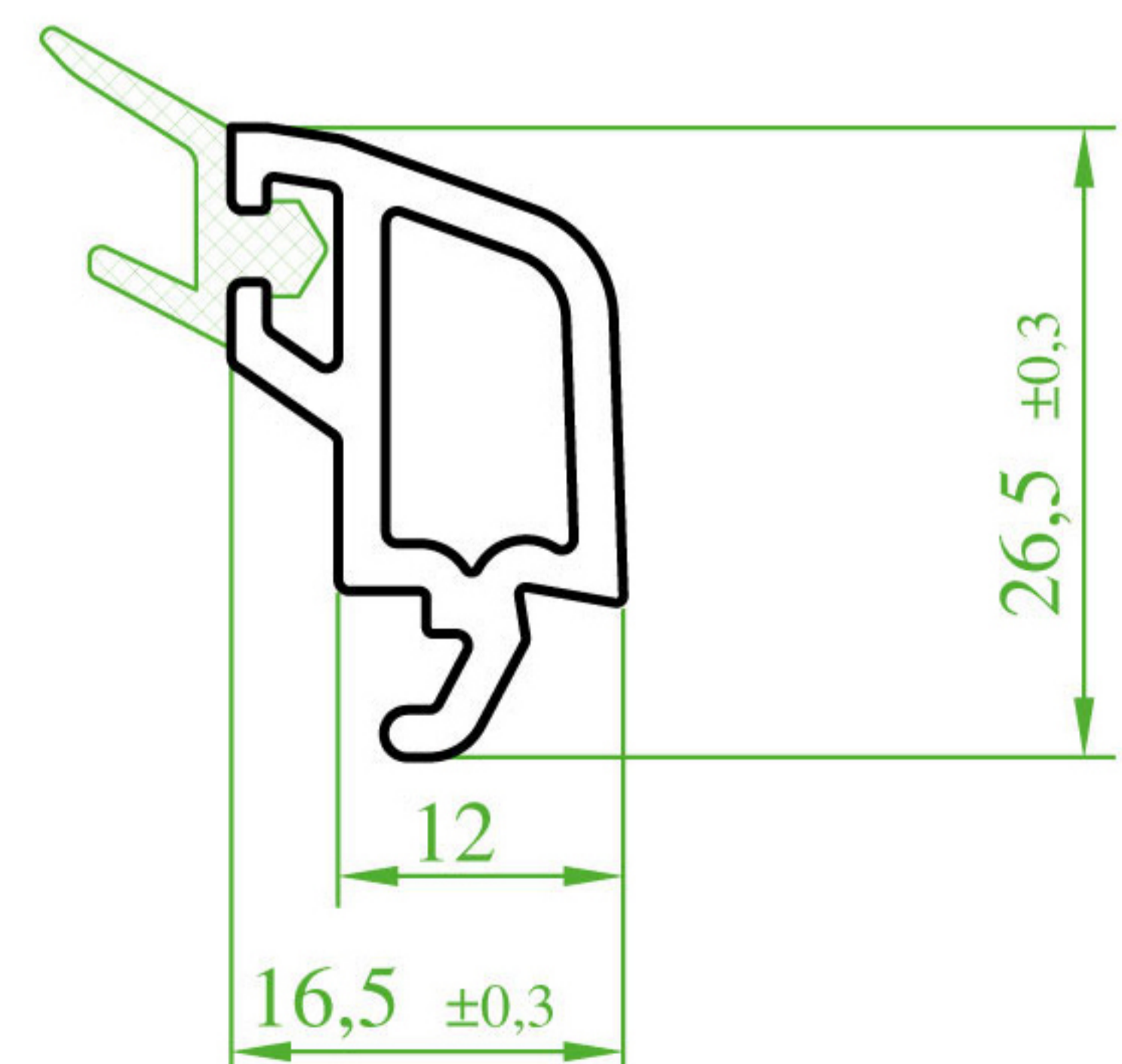

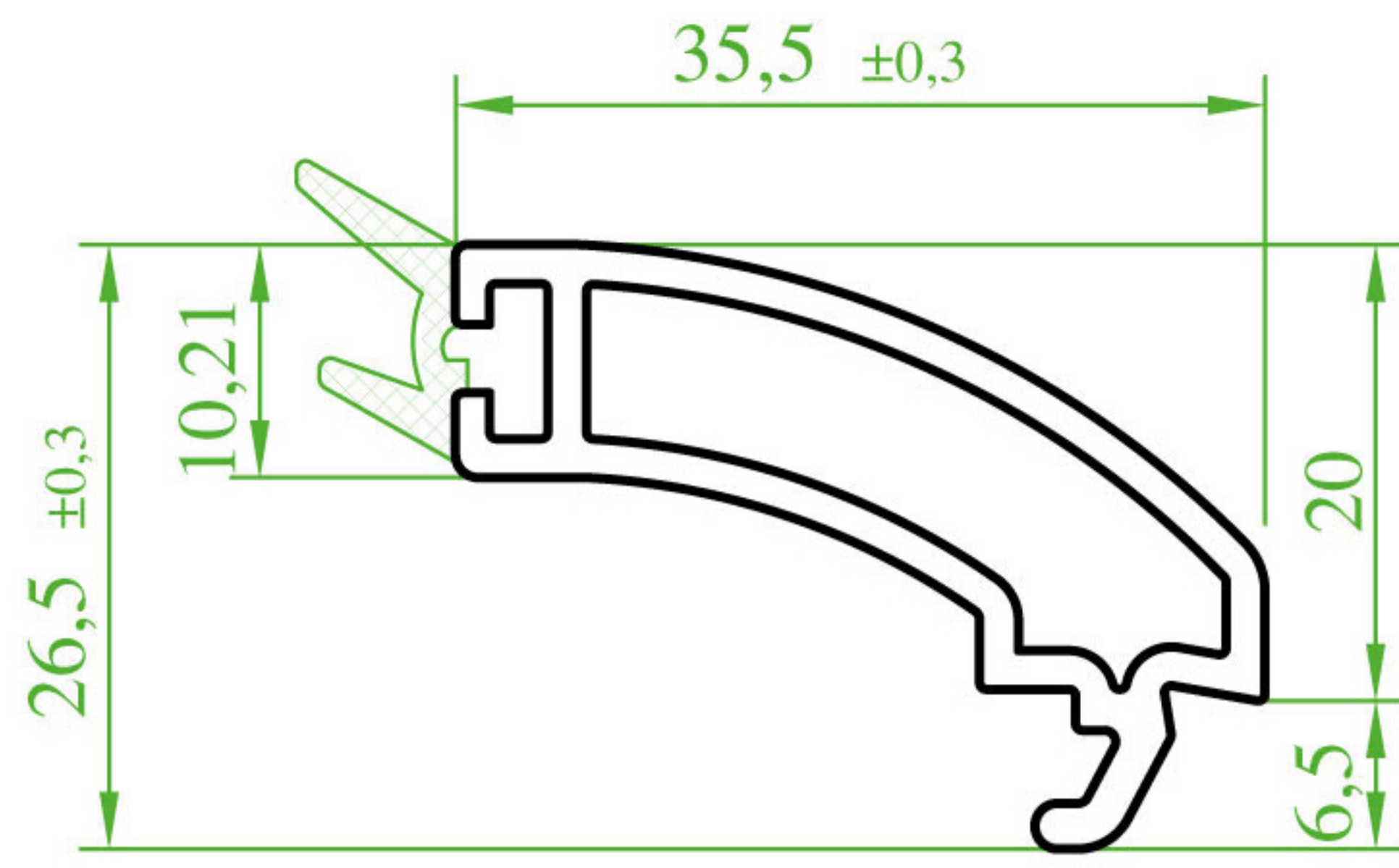

(ST 6530)

“GROSSTEC” Yap. Con. Tek Cam Çıtası” (4 mm)

“GROSSTEC” Single Glass Lath with Adhesive Seal (4 mm) (4 mm)

“GROSSTEC” Приклеивающийся штапик с уплотнителем для
одинарного стекла (4 мм)

ماسکه زجاج (مفرد) 4 ملم مع فتيل لاصق

Ö:1/1

S:1/1

P-P:1/1

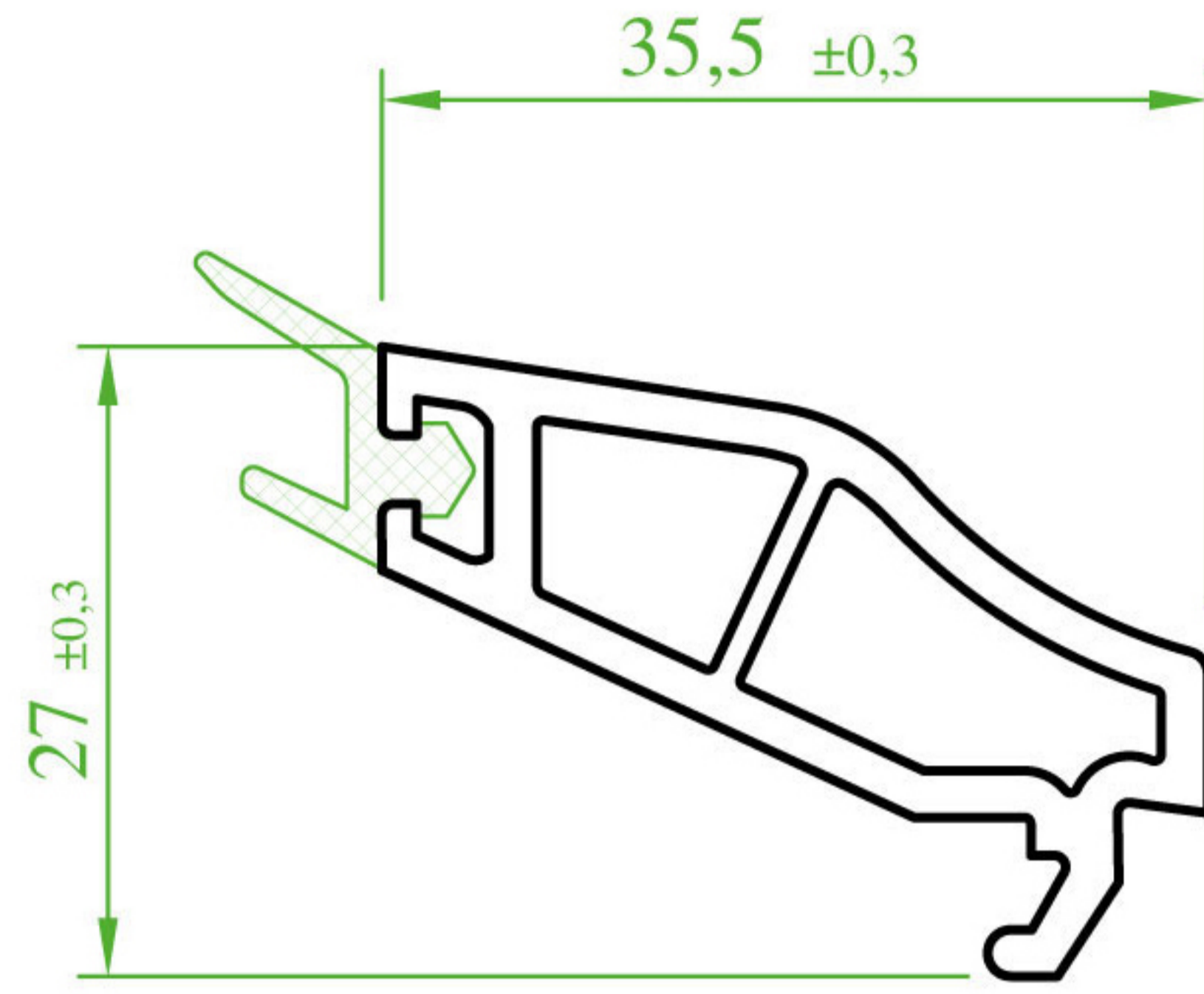

(ST 6550)

“GROSSTEC” Yap. Con. Dek. Tek Cam Çıtası” (4 mm)

“GROSSTEC” Decorative Single Glass Lath with Adhesive Seal (4 mm)

“GROSSTEC” Декоративный штапик для одинарного стекла,
с приклеивающимся уплотнителем” (4мм)

ماسکه زجاج (مفرد) 4 ملم موديل ديكوري مع فتيل لاصق

Ö : 1/1

S : 1/1

P-P : 1/1

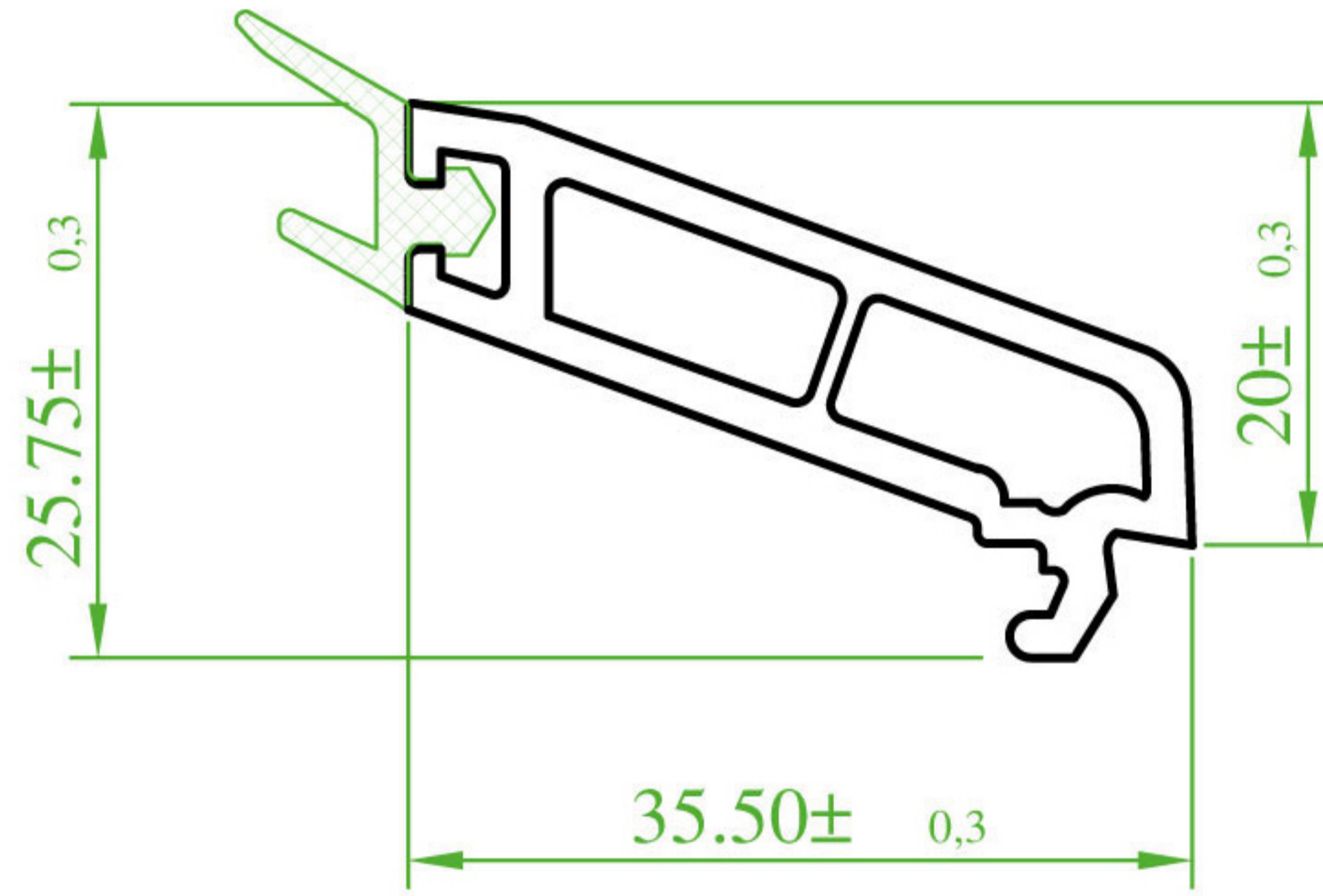

(ST 6520)

“GROSSTEC” Yap. Con. Tek Cam Çıtası” (4 mm)

“GROSSTEC” Single Glass Lath with Adhesive Seal (4 mm) (4 mm)

“GROSSTEC” Приклеивающийся штапик с уплотнителем для
одинарного стекла (4 мм)

ماسکه زجاج (مفرد) 4 ملم مع فتيل لاصق

Ö:1/1

S:1/1

P-P:1/1

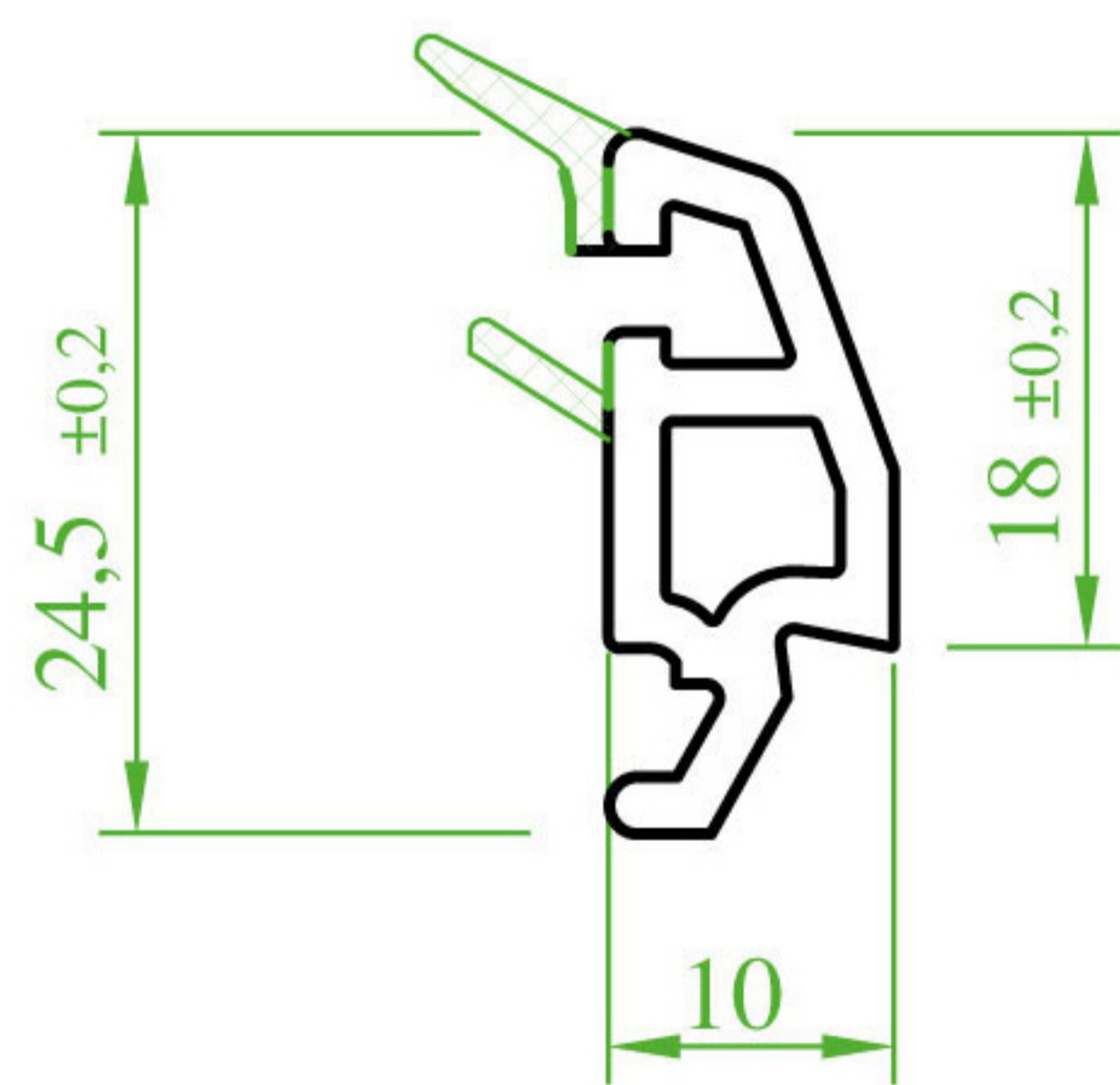

(ST 7460)

“GROSSTEC” Yap. Con. Üç Cam Çıtası (32 mm)

“GROSSTEC” Three Glass Lath with Adhesive Seal (32 mm)

“GROSSTEC” Приклеивающийся штапик с уплотнителем
для тройного стекла (32 мм)

ماسکه زجاج (ثلاثي) 32 ملم مع فتيل لاصق

Ö : 1/1

S : 1/1

P-P : 1/1